

Stowell solutions for domestic floors

D1

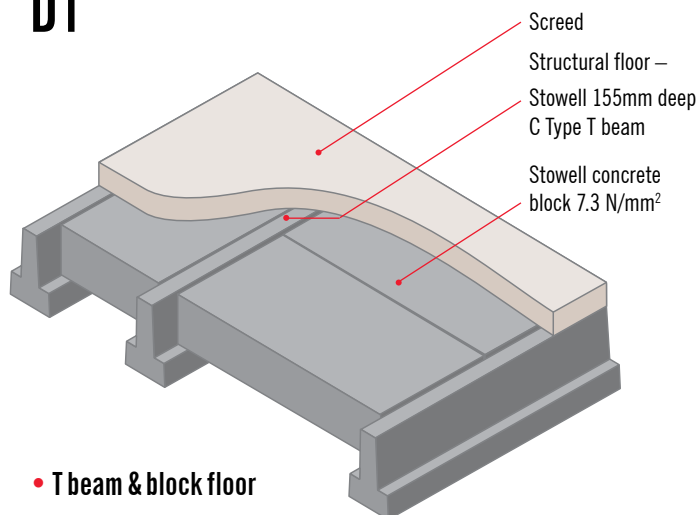

- **T beam & block floor**
(ceiling not shown)

D2

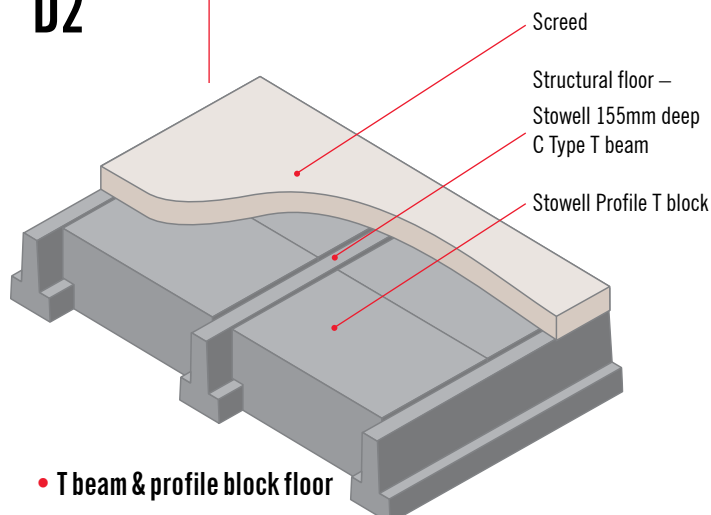

- **T beam & profile block floor**
(ceiling not shown)

D3

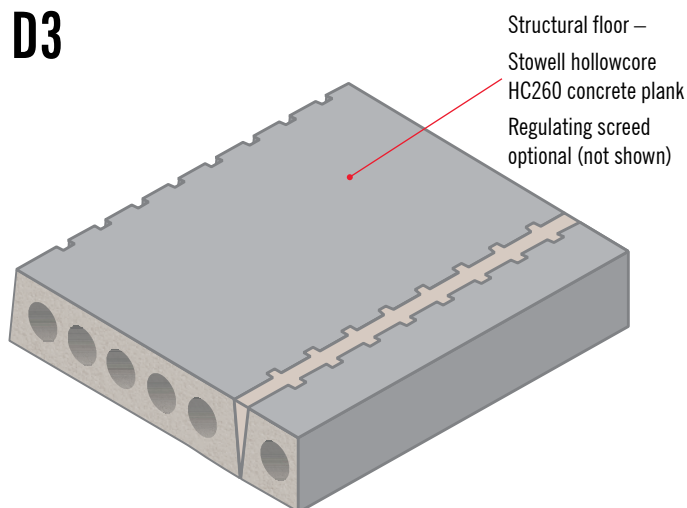

- **precast concrete plank**
(ceiling finish optional (not shown))

D4

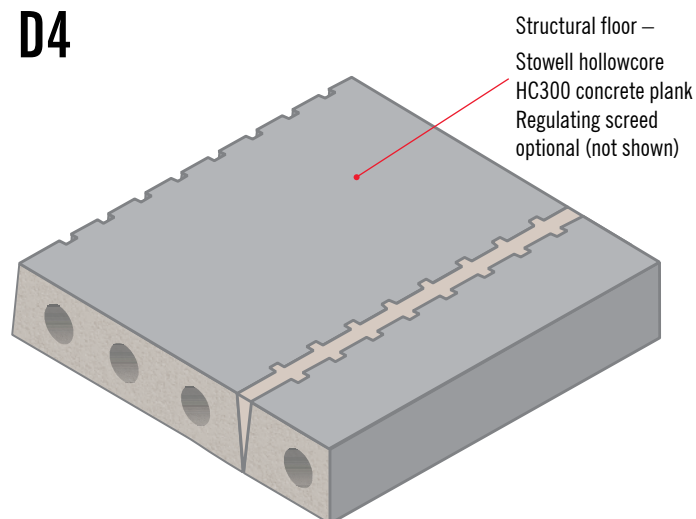

- **precast concrete plank**
(ceiling finish optional (not shown))

D5

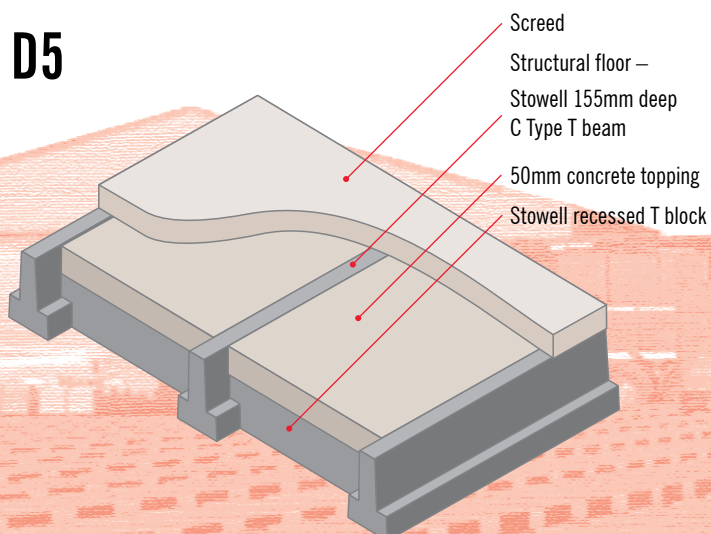

- **T beam & recessed profile block floor**
(ceiling not shown)

Part E (resistance to passage of sound) of the Building Regulations (England and Wales) Section 5: Internal walls and floors for new buildings, requires a minimum floor mass per unit area. For T beam and block the floor mass is 220kg/m² and for hollowcore concrete planks the requirement is a minimum 180kg/m².

STOWELL
CONCRETE LIMITED

11/11

www.stowellconcrete.co.uk