

# Stowell solutions for separating floors to help satisfy Robust Details part E

## E-FC-1

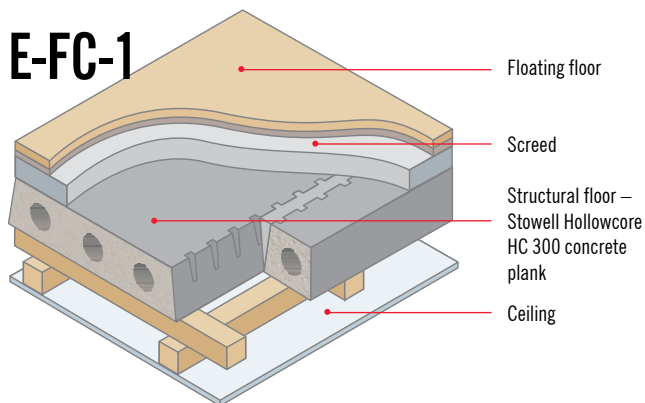

Floating floor

Screed

Structural floor –  
Stowell Hollowcore  
HC 300 concrete  
plank

Ceiling

- precast concrete plank
- screed

## E-FC-1(RSC)

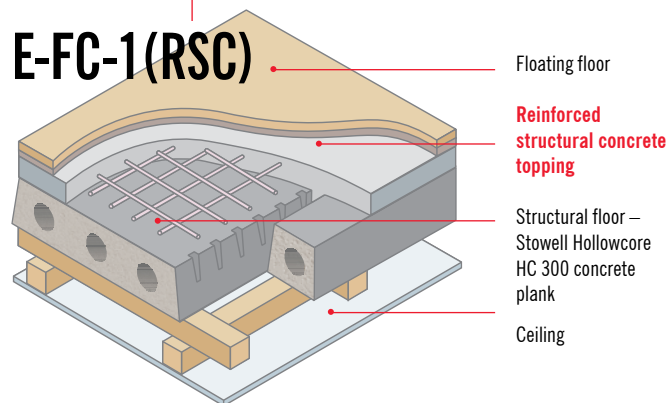

Floating floor

Reinforced  
structural concrete  
toppingStructural floor –  
Stowell Hollowcore  
HC 300 concrete  
plank

Ceiling

- precast concrete plank
- reinforced structural concrete topping

## E-FC-4

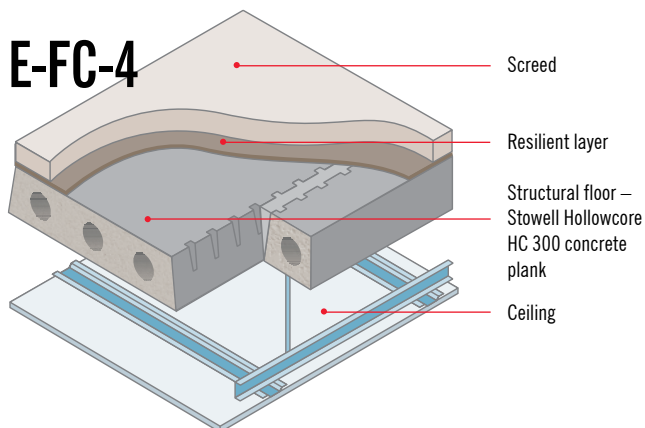

Screed

Resilient layer

Structural floor –  
Stowell Hollowcore  
HC 300 concrete  
plank

Ceiling

- precast concrete plank
- screed laid on Collecta YELOfon HD10+ resilient layer

## E-FC-5

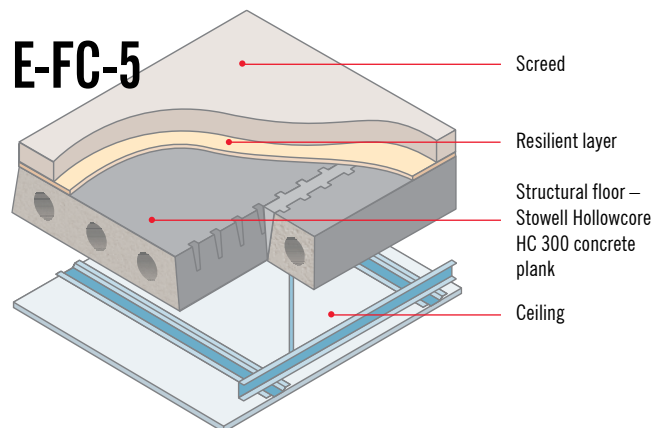

Screed

Resilient layer

Structural floor –  
Stowell Hollowcore  
HC 300 concrete  
plank

Ceiling

- precast concrete plank
- screed laid on Thermal Economics IsoRubber resilient layer

## E-FC-6

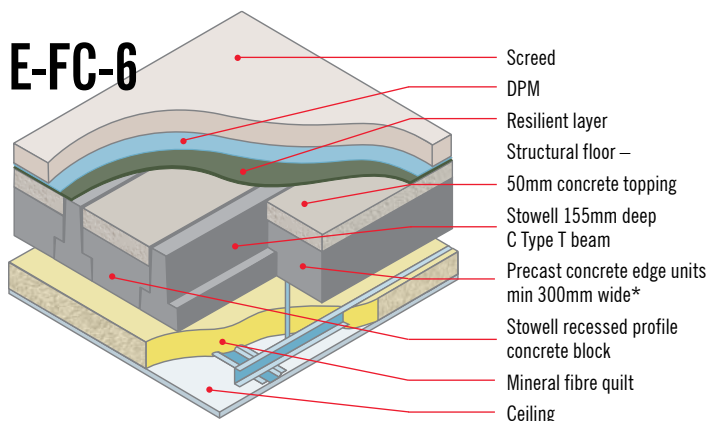

Screed

DPM

Resilient layer

Structural floor –

50mm concrete topping

Stowell 155mm deep  
C Type T beamPrecast concrete edge units  
min 300mm wide\*Stowell recessed profile  
concrete block

Mineral fibre quilt

Ceiling

- T beam and block floor with precast or insitu edge joists
- screed laid on Regupol E48 resilient layer system
- for use with dense aggregate block flanking walls only

## E-FC-7

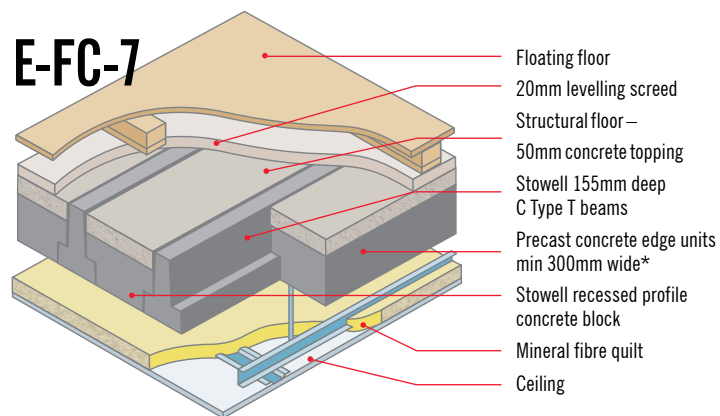

Floating floor

20mm levelling screed

Structural floor –

50mm concrete topping

Stowell 155mm deep  
C Type T beamsPrecast concrete edge units  
min 300mm wide\*Stowell recessed profile  
concrete block

Mineral fibre quilt

Ceiling

- T beam and block floor with precast or insitu edge joists
- using floating floor treatments
- for use with dense aggregate block flanking walls only

Robust Details are construction solutions which provide an alternative to pre-completion sound testing as a method of complying with Part E (resistance to the passage of sound) of the Building Regulations (England and Wales). Stowell concrete products enable builders to meet these regulations – provided the correct treatments are followed – when constructing new-build attached dwellings, flats and apartments. A synopsis of the construction treatments is provided above, with full details available from Robust Details Ltd (telephone 0870 240 8209 or [www.robustdetails.com](http://www.robustdetails.com)).

\*Stowell Hollowcore HC300 can be used

**STOWELL**  
CONCRETE LIMITED

11/11

[www.stowellconcrete.co.uk](http://www.stowellconcrete.co.uk)

# Stowell solutions for separating floors to help satisfy Robust Details part E

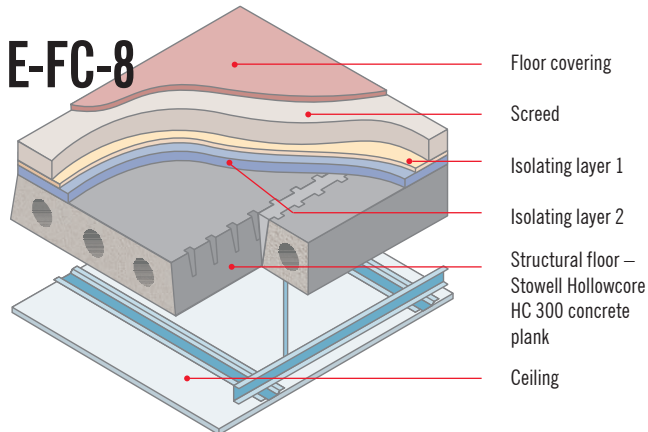

- precast concrete plank
- screed laid on isolating layers
- bonded resilient floor cover

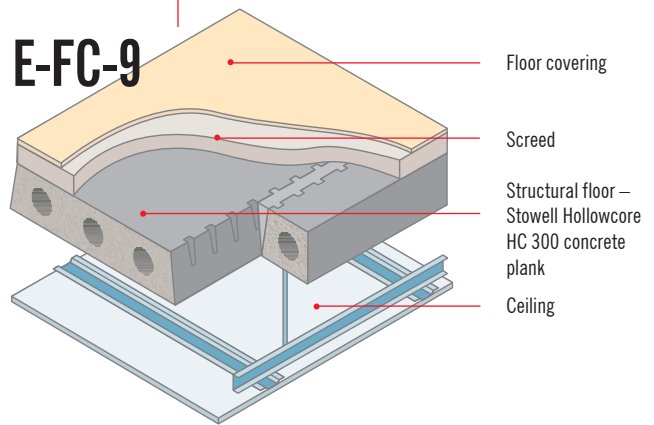

- precast concrete plank
- screed
- 3mm Thermal Economics IsoRubber top

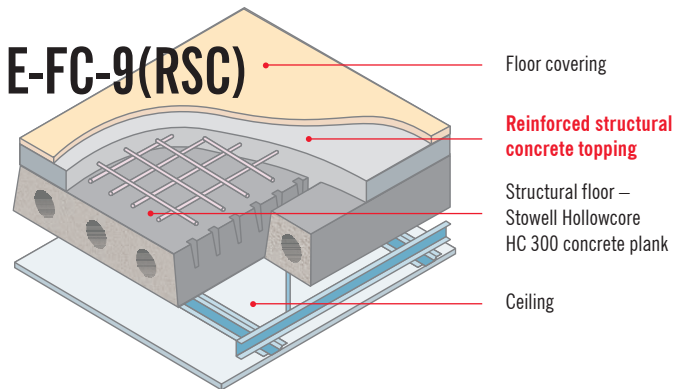

- precast concrete plank
- reinforced structural concrete
- 3mm Thermal Economics IsoRubber top

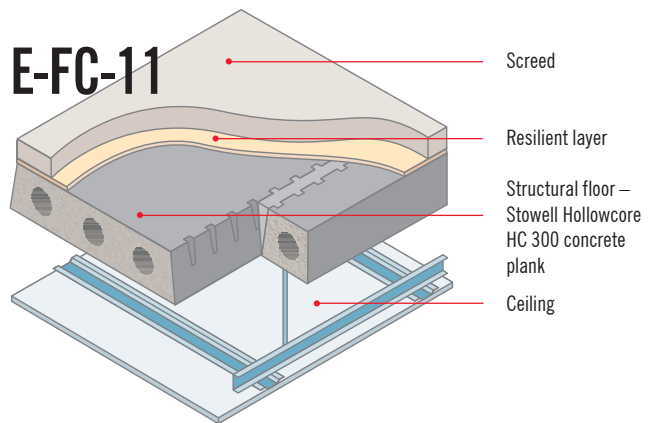

- precast concrete plank
- screed laid on Tranquilt® resilient layer

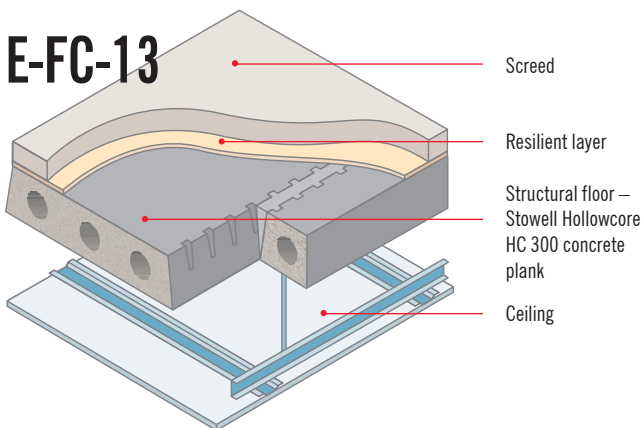

- precast concrete plank
- screed laid on Thermal Economics IsoRubber resilient layer

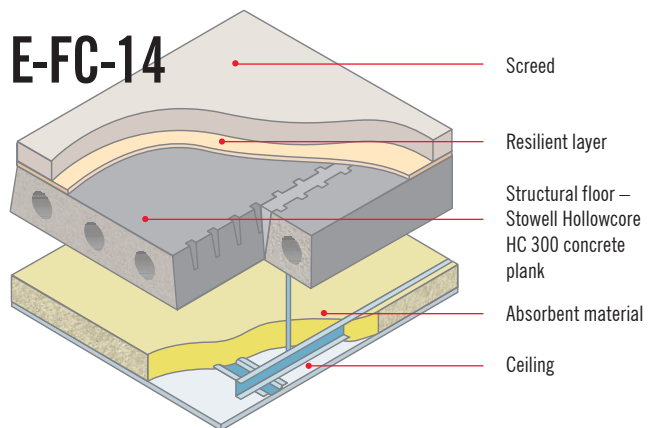

- precast concrete plank
- screed laid on Thermal Economics IsoRubber Code layer

Robust Details are construction solutions which provide an alternative to pre-completion sound testing as a method of complying with Part E (resistance to the passage of sound) of the Building Regulations (England and Wales). Stowell concrete products enable builders to meet these regulations – provided the correct treatments are followed – when constructing new-build attached dwellings, flats and apartments. A synopsis of the construction treatments is provided above, with full details available from Robust Details Ltd (telephone 0870 240 8209 or [www.robustdetails.com](http://www.robustdetails.com)).

**STOWELL**  
CONCRETE LIMITED

Arnolds Way, Yatton, Bristol BS49 4QN  
also at Holcombe, Cheddar & Weston-s-Mare  
Tel: 01934 834000 Fax: 01934 835474  
[www.stowellconcrete.co.uk](http://www.stowellconcrete.co.uk)

02/12