

Concrete pre-stressed T beams (concrete joists)

We manufacture and supply 155mm concrete pre-stressed T beams. When these are used with standard or Stowell profile blocks they provide a quick, simple and economical suspended flooring system. They are ideal for most types of housing and low-rise buildings.

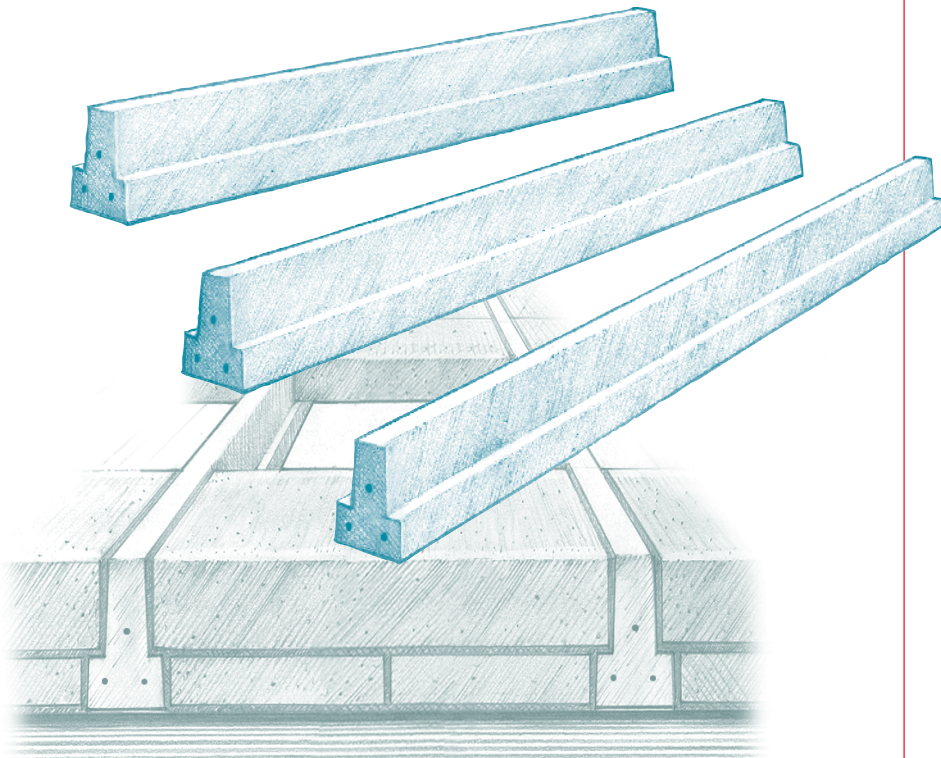

Typical build up of closure and flooring blocks using the Stowell T beam System

Stowell T beams, available from stock, are manufactured at our works using a pre-stressed wet-cast system.

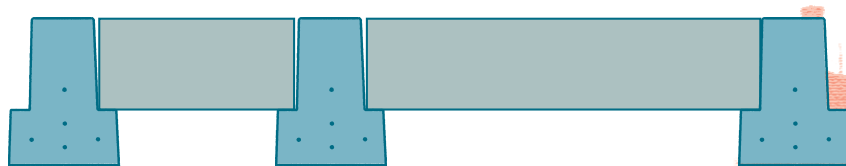

Our 155mm deep T beams are available in two different wire formats:

- Type 3C 4500mm max clear span
- Type 5C 6000mm max clear span

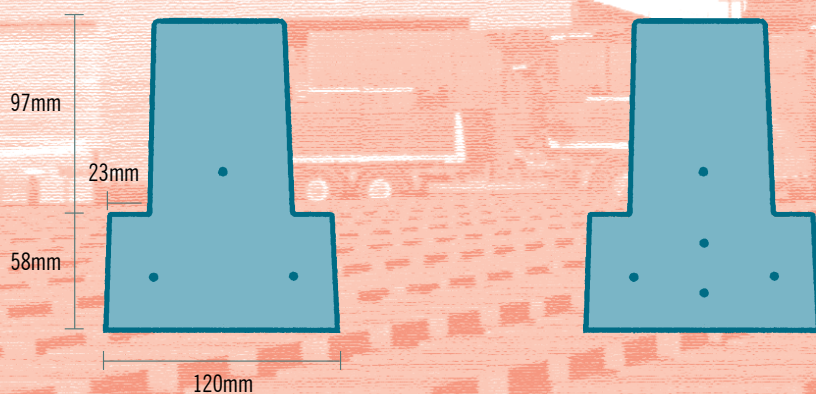

The Stowell T beam flooring system offers you the following benefits...

TIMESAVING

'Dry' construction speeds up building time and provides an immediate working platform.

ALL WEATHER

No delays due to bad weather. Can be installed in adverse weather conditions.

STORAGE & HANDLING

Easily stored and handled on-site prior to installation.

HIGHLY DURABLE

Stowell T beams do not rot.

CAN BE EASILY INSTALLED

Does not require specialist skills.

COST EFFECTIVE

Ease and speed of erection provide a significant cost benefit to the contractor.

READILY AVAILABLE

All sizes are available ex-stock.

Stowell T beams are manufactured under a quality management system based on BS EN ISO 9001. Beams are designed and manufactured in accordance with BS 8110 parts 1 and 2: 1985.

All raw materials comply with the relevant British Standards. Beams are randomly assessed and tested to ensure they comply with the specifications.

For further information on design, manufacture, planned deliveries or technical advice please contact the Stowell Flooring department on 01934 834000 or direct dial on 01934 839594/95/96

STOWELL
CONCRETE LIMITED

11/11

www.stowellconcrete.co.uk