

Commercial slabs to BS EN 1339

HARDSTONE						
size mm	CHAMFERED SLABS				number	
	colour				per tonne	per pack
	grey	red	buff	black		
450×450×70	●				32	30
400×400×65	●				40	30
400×400×50	●				50	40
REINFORCED HEAVY DUTY SLABS						
600×600×70	●				14	13
450×600×70	●				24	13
LIMESTONE						
size mm	SQUARE EDGE SLABS				number	
	63mm SLABS				per tonne	per pack
900×600×63	●				13	15
750×600×63*	●				16	15
600×600×63*	●				20	15
600×450×63	●				26	15
600×300×63	●				40	15
50mm SLABS						
900×600×50	●		●		16	20
900×300×50**	●				32	20
750×600×50	●		●		20	20
600×600×50	●	●	●	●	24	20
450×600×50	●		●		32	40
450×450×50	●		●		40	40
300×600×50	●		●		48	20
300×300×50**	●				96	120
BARFACED ANTI-SLIP PAVING						
900×600×50	●				16	20
600×600×50	●		●		24	20
AVON & SOMERSET SLABS						
600×600×38	●	●	●	●	30	25
450×450×32	●	●	●	●	65	60
DIAMOND SLABS						
450×450×32	●	●	●	●	65	60

* Available with fibre reinforcement

** Cut product

Our hydraulically pressed paving range is available in a variety of sizes, thicknesses and finishes.

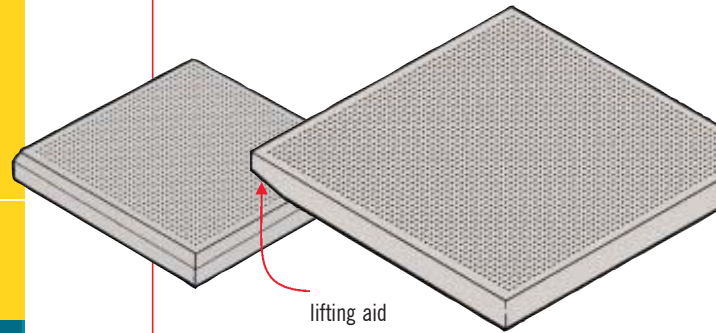

CHAMFERED

REINFORCED

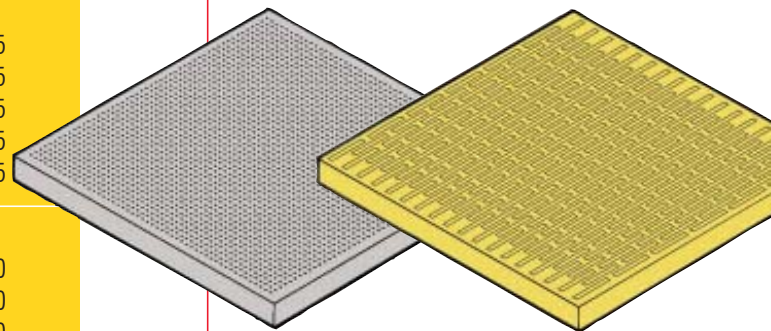

STANDARD

BARFACE

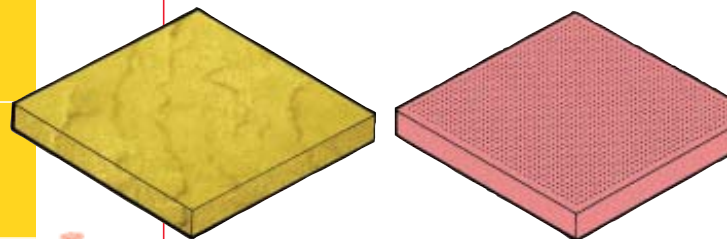

AVON

SOMERSET

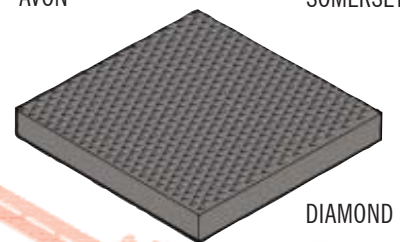

DIAMOND

STOWELL
CONCRETE LIMITED

07/09

www.stowellconcrete.co.uk